

Series 115 NPT Basket Strainer with O-Ring Seal Cast Iron, Cast Steel, and Cast 316 Stainless Steel

Operating Limits on Seal Gaskets

ELASTOMER	°F	°C
Buna-N	257	125
EPDM	302	150
Viton ¹	437	225
Silicone ²	482	250

- 1 Supplied as standard.
- 2 Do not use for paint applications.

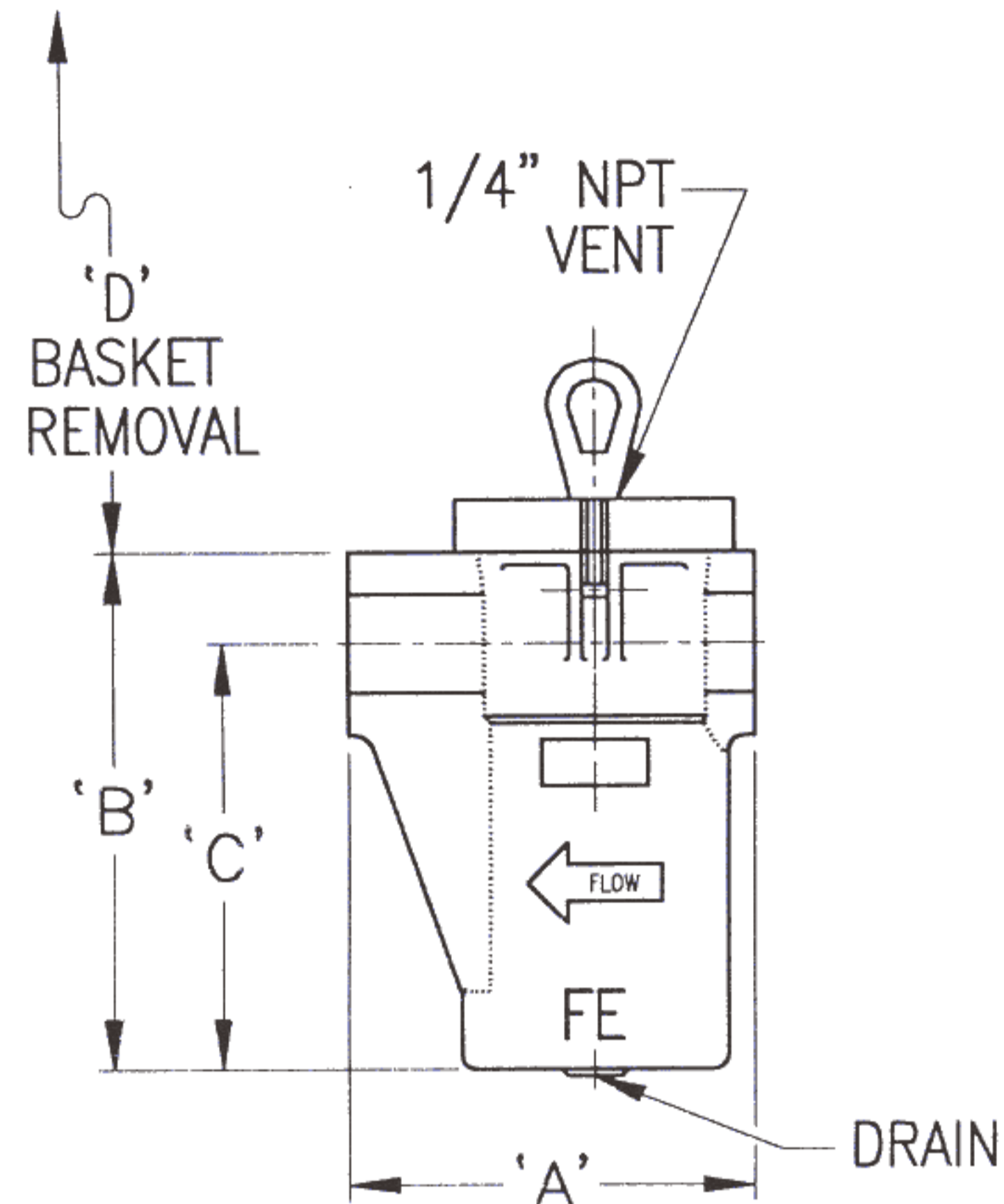

Standard Construction

	Cast Iron	Cast Steel	Cast 316 Stainless Steel
Body	Class 30 ASTM A126B	A216 Grade WCB	A351 Grade CF8M
Cover	Class 30 ASTM A126B	A216 Grade WCB	A351 Grade CF8M
O-Ring	Viton	Viton	Viton
Basket	Available in 1/32", 1/16", or 1/8" perforations and 40 mesh and 80 mesh - Stainless Steel		

Options:

- Baskets are available in other materials, perforations, and meshes, please consult the factory or your local sales representative.
- British thread sizes (BSP) available upon request.

Size Connection	A	B	C	D	Drain NPT	Weight	Cv
3/4" NPT 20 mm	5" 127.0 mm	6-1/4" 158.8 mm	5" 127.0 mm	6" 152.4 mm	1/4" NPT	11 lbs. 5 kg.	15 GPM 57 LPM
1" NPT 25 mm	5" 127.0 mm	6-1/4" 158.8 mm	5" 127.0 mm	6" 152.4 mm	1/4" NPT	11 lbs. 5 kg.	25 GPM 95 LPM
1-1/4" NPT 32 mm	7-5/8" 193.7 mm	9-3/4" 247.7 mm	8" 203.2 mm	9" 228.6 mm	1/4" NPT	33 lbs. 15 kg.	32 GPM 121.6 LPM
1-1/2" NPT 38 mm	7-5/8" 193.7 mm	9-3/4" 247.7 mm	8" 203.2 mm	9" 228.6 mm	1/4" NPT	33 lbs. 15 kg.	53 GPM 201.4 LPM
2" NPT 50 mm	7-5/8" 193.7 mm	9-3/4" 247.7 mm	8" 203.2 mm	9" 228.6 mm	1/4" NPT	33 lbs. 15 kg.	85 GPM 323 LPM

Dimensions subject to change without notice, apply for certified drawings.

Pressure vs. Temperature (ANSI) Maximum Operating Pressure and Temperature W.O.G. Service

