

SERIES 180 BUTT WELD CAST STEEL & CAST 316 STAINLESS “Y” STRAINERS SCHEDULE 160 BORE

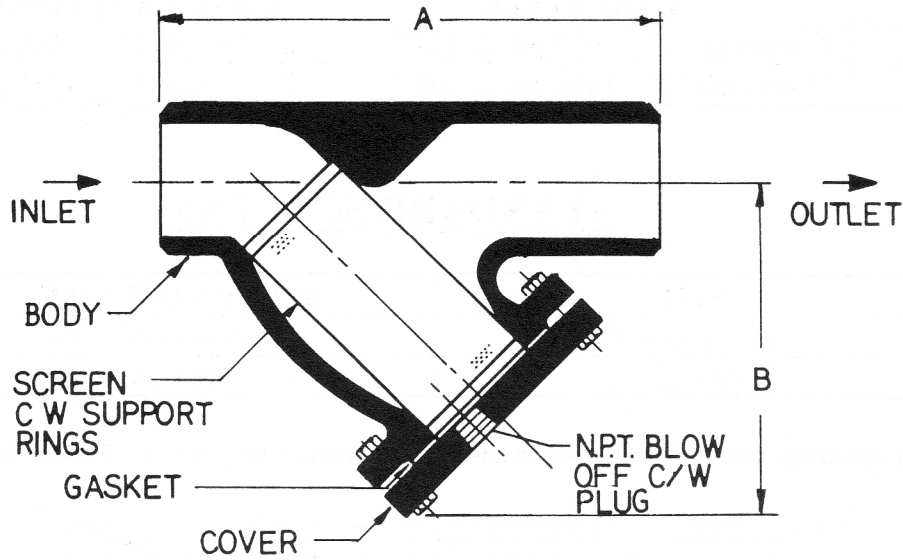

SIZE	A	B	C _v	BLOW OFF	WEIGHT
2" 50 mm	9-5/8" 244.5 mm	5-3/4" 146 mm	75 GPM 285 LPM	1/2" NPT 15 mm	32 lbs. 14.5 kg
3" 80 mm	12-1/4" 311.2 mm	7-1/2" 190.5 mm	175 GPM 665 LPM	1" NPT 25 mm	63 lbs. 28.6 kg
4" 100 mm	15-1/4" 387.4 mm	9-1/2" 241.3 mm	300 GPM 1140 LPM	1" NPT 25 mm	119 lbs. 54 kg
6" 150 mm	20-7/8" 530.2 mm	12-7/16" 316 mm	700 GPM 2650 LPM	1-1/2" NPT 40 mm	165 lbs. 74.8 kg
8" 200 mm	24-1/8" 612.8 mm	16-1/4" 412.8 mm	1010 GPM 3825 LPM	1-1/2" NPT 40 mm	290 lbs. 131.5 kg

Dimensions subject to change without notice, apply for certified drawings.

Additional sizes available upon request.

November 2002

STANDARD CONSTRUCTION

	CAST STEEL	CAST 316 STAINLESS STEEL
Body and Cover	ASTM A216 Grade WCB	ASTM A351 Grade CF8M
Gasket	Non-Asbestos	Teflon
Screen	Stainless Steel	Stainless Steel

MAXIMUM OPERATING PRESSURES AND TEMPERATURES

	CAST STEEL	CAST 316 STAINLESS STEEL
Steam	2" through 12" - 600 psi @ 838°F	2" through 12" - 600 psi @ 1125°F
W.O.G.	2" through 12" - 1480 psi @ 100°F	2" through 12" - 1235 psi @ 100°F

STANDARD SCREENS

SIZE	SCREEN OPENING
2" through 3"	0.045 perforations
4" through 12"	0.125 perforations

Other screen openings are available, please consult the factory or your local sales representative.

